



INSTRUCTIONS D'ASSEMBLAGE  
ASSEMBLY INSTRUCTIONS

---

**M**ONARCH  
SPECIALTIES INC.

# I 2419-1

---

ETAGERE -  
72"H / BLANC EN COIN

BOOKCASE -  
72"H / WHITE CORNER ACCENT ETAGERE



POUR DE L'ASSISTANCE OU POUR COMMANDER  
DES PIÈCES CONTACTEZ NOTRE DÉPARTEMENT  
DE SERVICE À LA CLIENTÈLE.

FOR ASSISTANCE OR TO ORDER PARTS  
CONTACT OUR CUSTOMER SERVICE DEPARTMENT

**WWW.MONARCHSERVICE.COM**

**LISTE DES PIÈCES**  
**PARTS LIST**

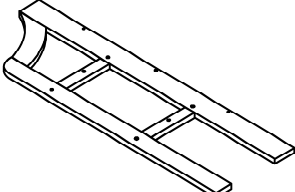
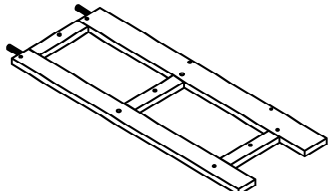
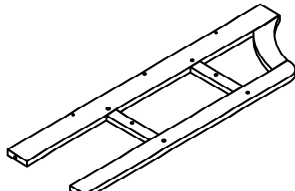
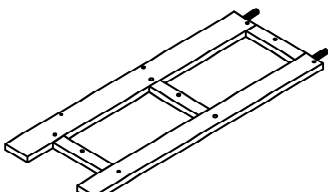
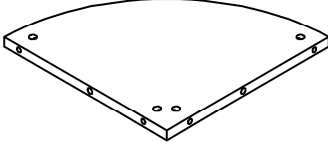
PIÈCE / PART #	IMAGE	DESCRIPTION	QTY / QTÉ
1		FRONT FACING LEFT LEG PATTE AVANT GAUCHE	1
2		FRONT FACING LEFT LEG PATTE AVANT GAUCHE	1
3		FRONT FACING RIGHT LEG PATTE AVANT DROITE	1
4		FRONT FACING RIGHT LEG PATTE AVANT DROITE	1
5		SHELF PANEL PANNEAU DE TABLETTE	2

**LISTE DES PIÈCES**  
**PARTS LIST**

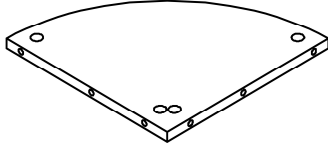
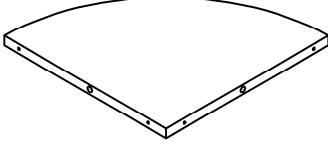
PIÈCE / PART #	IMAGE	DESCRIPTION	QTY / QTÉ
6		<p>SHELF PANEL PANNEAU DE TABLETTE</p>	2
7		<p>SHELF PANEL PANNEAU DE TABLETTE</p>	1

**LISTE DES PIÈCES DE MONTAGE**  
**HARDWARE LIST**

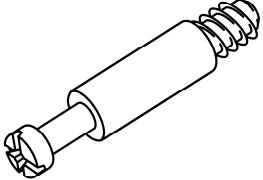
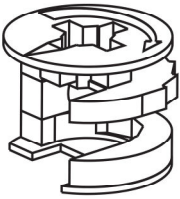
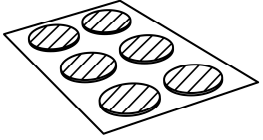
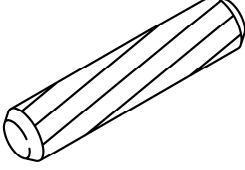
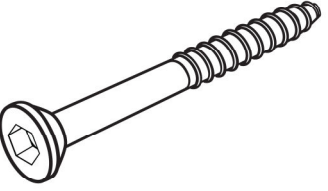
PIÈCE / PART #	IMAGE	DESCRIPTION	QTY / QTÉ
A		CAM LOCK SCREW - 1 1/8" VIS CAM LOCK - 1 1/8"	8
B		CAM LOCK CONNECTOR - Ø5/8" ÉCROU CAM LOCK - Ø5/8"	8
C		FINISHING STICKER - Ø7/8" COLLANT DE FINITION - Ø7/8"	12
D		WOOD DOWEL - Ø3/8" X 1" GOUJON DE BOIS - Ø3/8" X 1"	12
E		ASSEMBLING SCREW - 2 1/8" VIS D'ASSEMBLAGE - 2 1/8"	8

**LISTE DES PIÈCES DE MONTAGE**  
**HARDWARE LIST**

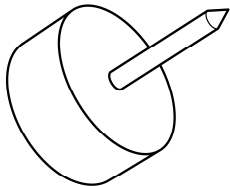
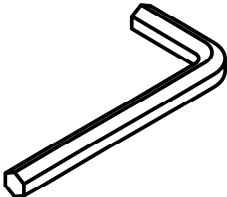
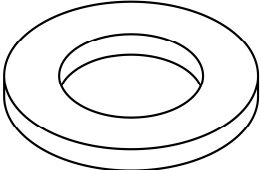
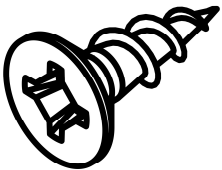
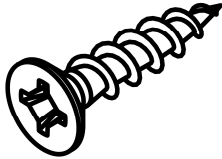
PIÈCE / PART #	IMAGE	DESCRIPTION	QTY / QTÉ
F		FLOOR PROTECTOR - Ø5/8" PROTECTEUR DE PLANCHER - Ø5/8"	4
G		HEX KEY CLÉ HEXAGONALE	1
H		METAL WASHER - Ø5/8" RONDELLE DE MÉTAL - Ø5/8"	8
I		ASSEMBLING SCREW - Ø1/8" X 1/2" VIS D'ASSEMBLAGE - Ø1/8" X 1/2"	4
J		ASSEMBLING SCREW - Ø1/8" X 1 3/8" VIS D'ASSEMBLAGE - Ø1/8" X 1 3/8"	8

**LISTE DES PIÈCES DE MONTAGE**  
**HARDWARE LIST**

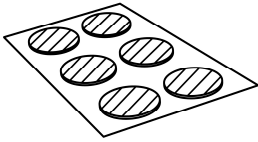
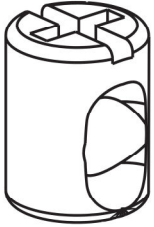
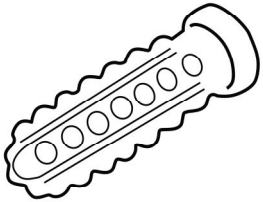
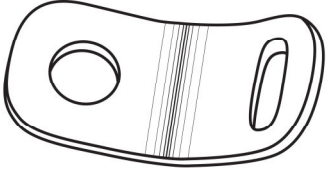
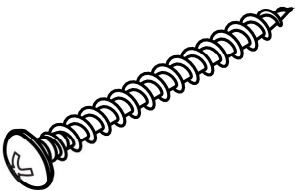
PIÈCE / PART #	IMAGE	DESCRIPTION	QTY / QTÉ
K		FINISHING STICKER - Ø1/2" COLLANT DE FINITION - Ø1/2"	16
L		BARREL NUT - Ø3/8" X 1/2" ÉCROU DE CANON - Ø3/8" X 1/2"	8
M		ANCHOR - Ø3/8" X 1 1/2" ANCRE - Ø3/8" X 1 1/2"	1
N		METAL BRACKET - 1/2" X 1/2" SUPPORT EN MÉTAL - 1/2" X 1/2"	2
O		ASSEMBLING SCREW - Ø1/8" X 1 1/2" VIS D'ASSEMBLAGE - Ø1/8" X 1 1/2"	1

**LISTE DES PIÈCES DE MONTAGE**  
**HARDWARE LIST**

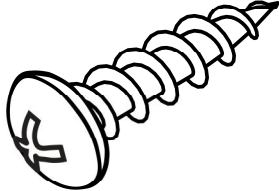
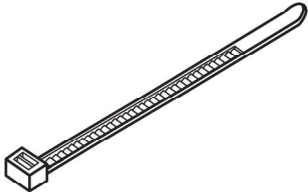
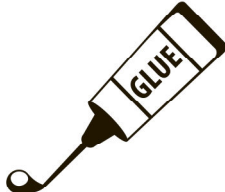
PIÈCE / PART #	IMAGE	DESCRIPTION	QTY / QTÉ
P		<p>ASSEMBLING SCREW - Ø1/8" X 1"</p> <p>VIS D'ASSEMBLAGE - Ø1/8" X 1"</p>	1
Q		<p>ZIP TIE - 7 3/4" X 1/8"</p> <p>ATTACHE AUTOBLOQUANTE - 7 3/4" X 1/8"</p>	1
R		<p>GLUE - 10G</p> <p>COLLE - 10G</p>	1



OUTIL DE VÉRIFICATION DE DIMENSIONS DES PIÈCES  
HARDWARE DIMENSIONS VERIFICATION TOOL





ÉTAPE / STEP 1

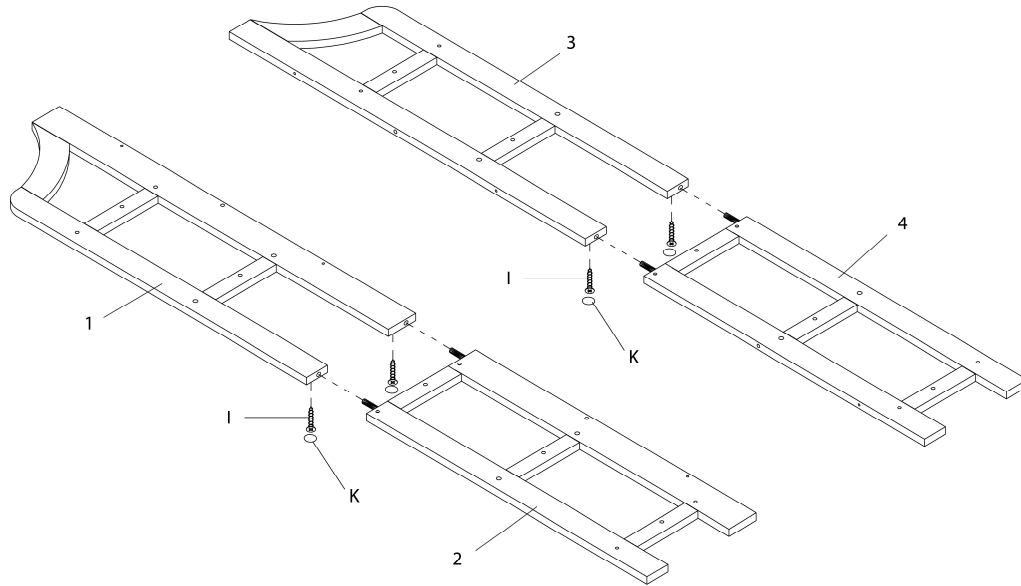

ÉTAPE / STEP 2

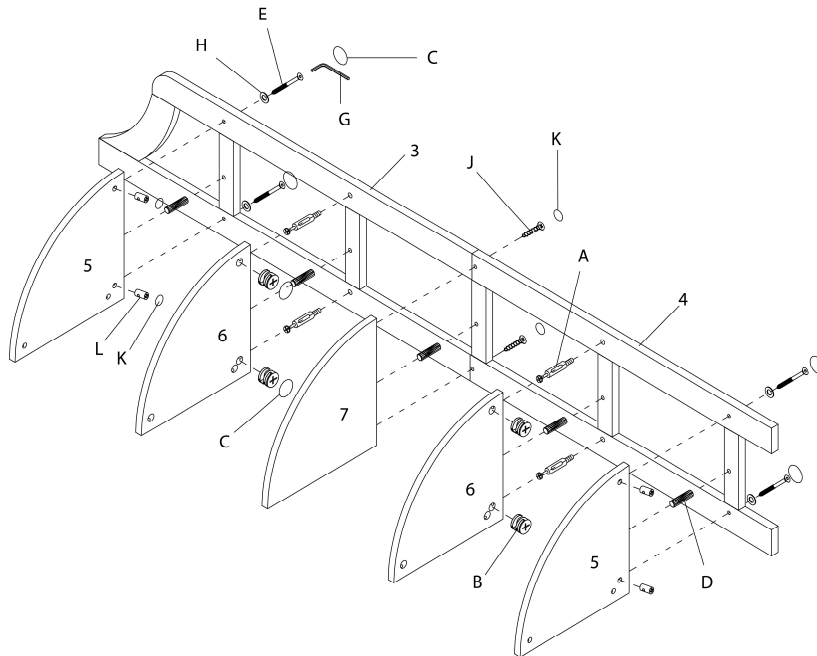

ÉTAPE / STEP 3

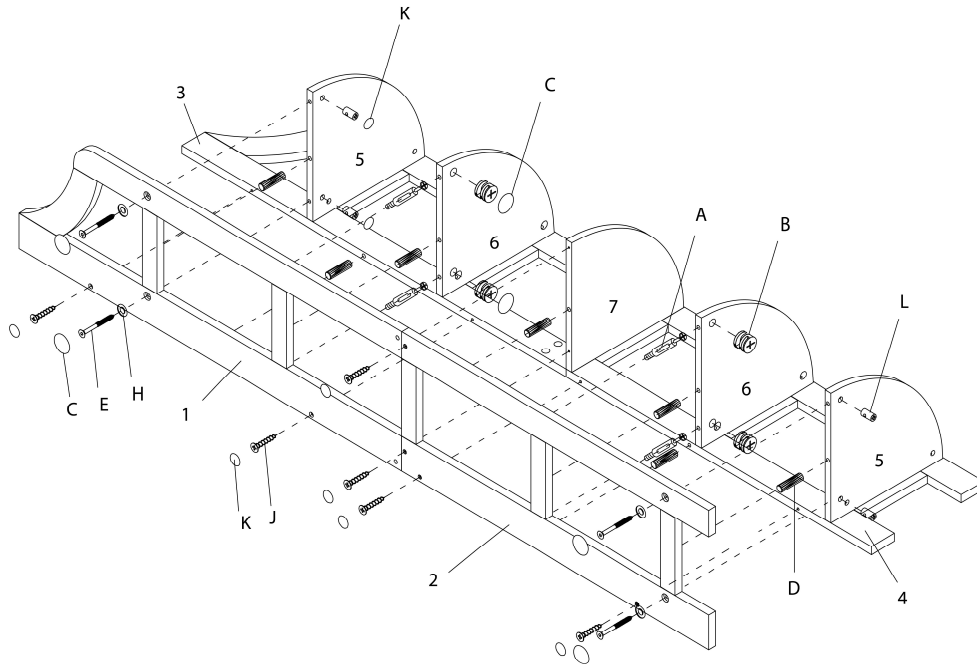

ÉTAPE / STEP 4

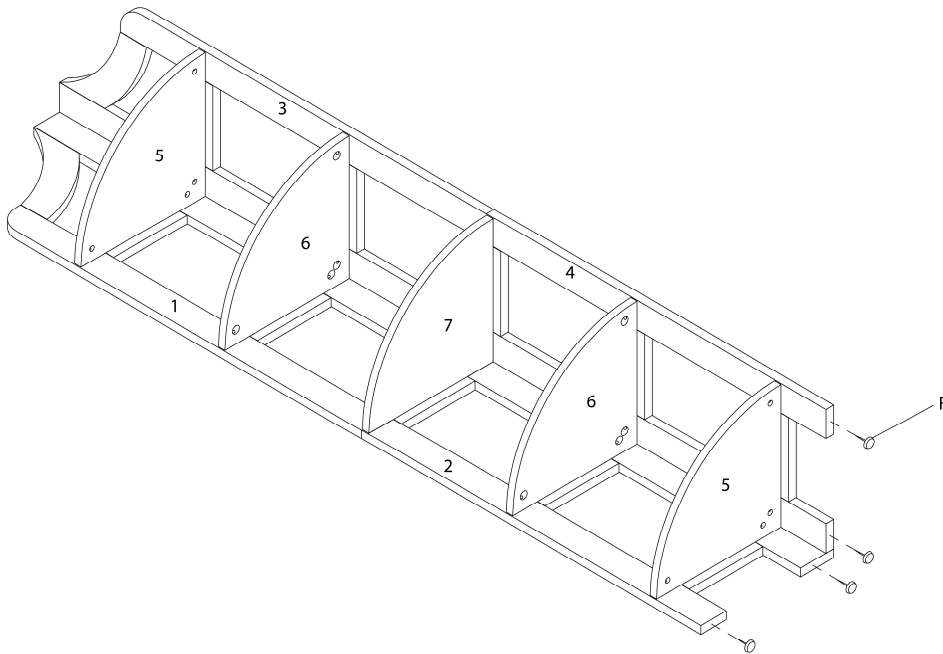

ÉTAPE / STEP 5

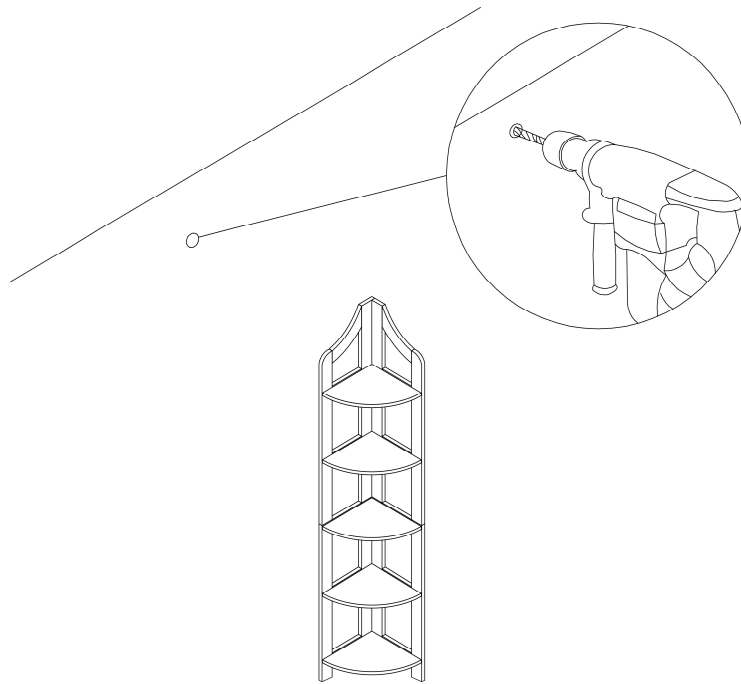

ÉTAPE / STEP 6

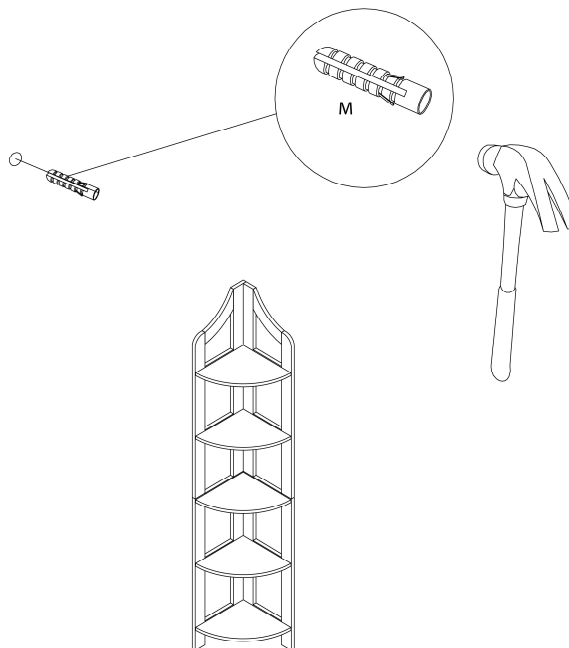

ÉTAPE / STEP 7

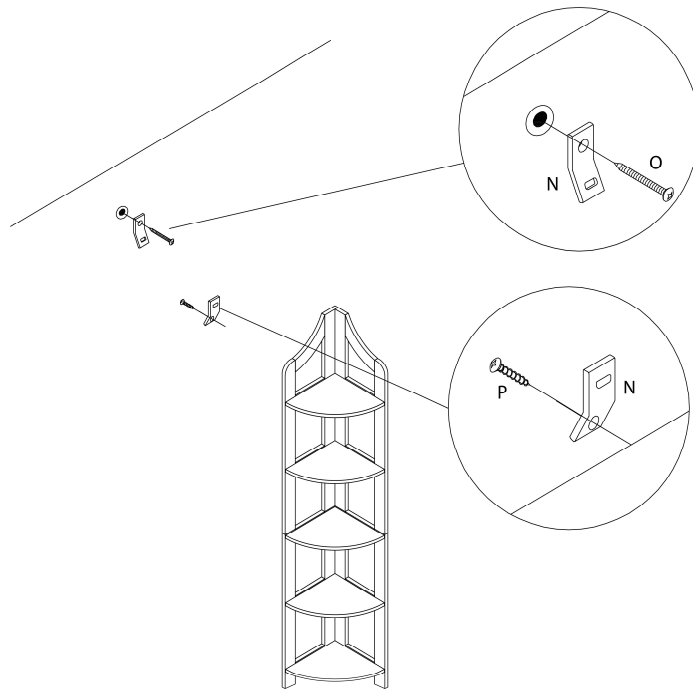

ÉTAPE / STEP 8

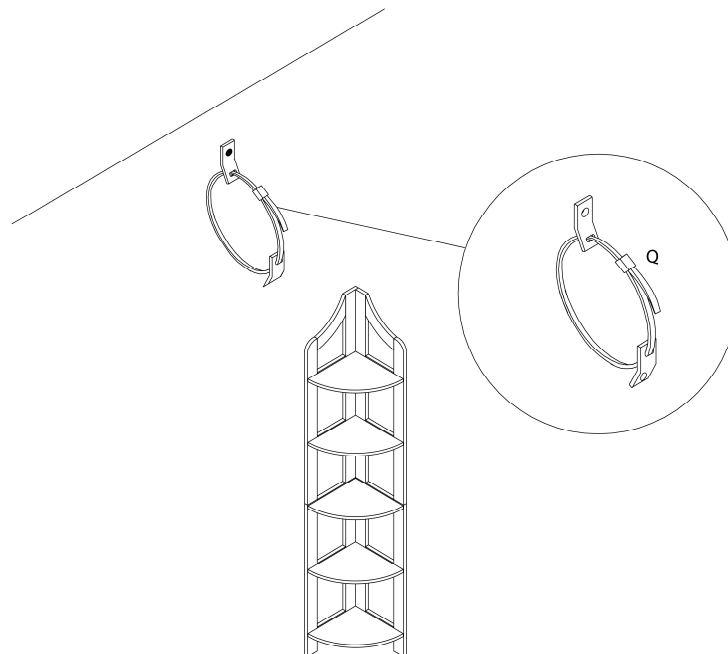

ÉTAPE / STEP 9

